

# Technical Guide: XAM Series - Add-on Coils for Use with Split-System Cooling and Heat Pumps

800 CFM to 1,800 CFM - 2 ton to 5 ton

---

York International Corporation, 5005 York Drive, Norman, OK 73069

6339553-UTG-A-0123

Supersedes: nothing

2023-01-03

A



# Contents

Description.....	5
Certification.....	5
Features.....	5
Nomenclature.....	7
Dimensions: XAM coils.....	8
Cooling capacity: XAM coils.....	9
Application factors.....	9
Application limitations.....	9
Static pressure versus airflow based on wet coil: XAM coils.....	10
Coil technical data: XAM coils.....	10
Airflow data: XAM coils.....	11



## Description

MaxAlloy™ aluminum indoor coils are specially designed for installation with our residential furnaces or modular air handlers as part of a matched air conditioning or heat pump system.

Our XAM residential indoor coils can be applied with electronic expansion valves (EEVs). Refer to the *Technical Guide* for the matched outdoor unit to determine the required indoor expansion device for your specific application.

XAM series full-cased coils are multi-positional and are suitable for vertical and horizontal applications.

Due to continuous product improvement, specifications are subject to change without notice. Visit us on the web at [www.simplygettingthejobdone.com](http://www.simplygettingthejobdone.com). Additional rating information can be found at [www.ahridirectory.org](http://www.ahridirectory.org).

**This document is only for distribution use - it is not to be used at point of retail sale.**

## Certification



## Features

### Rigid case construction

The rigid case construction provides structural support and eliminates screw heads protruding from the side of the cabinet that could damage property during installation.

### Cabinet

The cabinet is constructed of heavy gauge galvanized steel with a primer and finish coat that provides a high-quality corrosion resistant finish.

### MaxAlloy™ coil

These long-life aluminum coils are built to deliver lasting performance, efficiency, and reliability.

### Foil-faced insulation

The cabinet is insulated with a single piece of cleanable foil-faced insulation. The cabinet is designed so that all edges of the insulation are contained.

### Electronic expansion valve (EEV)

An EEV is factory installed on select models and sized to match with specific high-efficiency variable capacity outdoor units.

**Compact cabinet**

With the coil and access doors removed, the cabinet has a 20.5 in. casing depth in all models, allowing ease of access in attics and applications where space is constrained.

**Thermoset drain pan**

The drain pan is corrosion and UV resistant with a positive slope for proper drainage. The low water retention design maximizes indoor air quality and consumer comfort.

**Low leakage cabinet design**

Fully gasketed doors minimize air leakage to no more than 2% when measured at 1 in. W.C. external static pressure, minimizing conditioned air leakage and infiltration.

**Duct flange**

An integral duct flange is part of the coil casing for easy installation.

# Nomenclature

**Table 1: Nomenclature**

<b>Product type</b>	<b>X</b>	<b>X</b> = Coil (indoor)	
<b>Coil type</b>	<b>A</b>	<b>A</b> = A coil	
		<b>S</b> = Slab coil	
<b>Configuration</b>	<b>M</b>	<b>F</b> = Full cased, upflow or downflow	
		<b>H</b> = Full cased, horizontal	
		<b>U</b> = Uncased, upflow or downflow	
		<b>D</b> = Horizontal duct	
		<b>M</b> = Full-cased, multi-position	
<b>Cabinet width</b>	<b>B</b>	<b>A</b> = 14.5 in.	
		<b>B</b> = 17.5 in.	
		<b>C</b> = 21.0 in.	
		<b>D</b> = 24.5 in.	
<b>Nominal capacity</b>	<b>24</b>	<b>18</b> = 1.5 ton	<b>42</b> = 3.5 ton
		<b>24</b> = 2 ton	<b>48</b> = 4 ton
		<b>30</b> = 2.5 ton	<b>60</b> = 5 ton
		<b>36</b> = 3 ton	
<b>Slab size</b>	<b>D</b>	<b>A</b> = 2R-14-18	<b>F</b> = 3R-24-14
		<b>B</b> = 2R-16-18	<b>G</b> = 3R-28-12
		<b>C</b> = 2R-20-18	<b>H</b> = 3R-32-12
		<b>D</b> = 3R-20-14	<b>J</b> = 4R-28-12
		<b>E</b> = 3R-22-14	
<b>Metering device</b>	<b>E1</b>	<b>BA-BW</b> = TXV part number	
		<b>E1-E9</b> = EEV part number	
		<b>XX</b> = No valve (flex coil)	
<b>Accessories</b>	<b>N</b>	<b>S</b> = A2L sensor	
		<b>N</b> = None (no sensor)	
<b>Generation (major revision)</b>	<b>1</b>	<b>1</b> = First generation	
		<b>2</b> = Second generation	
<b>Style letter (minor revision) not used for ordering</b>	<b>A</b>	<b>A</b> = Style A	
		<b>B</b> = Style B	

# Dimensions: XAM coils

Figure 1: Dimensions - XAM full-cased horizontal left or right coil

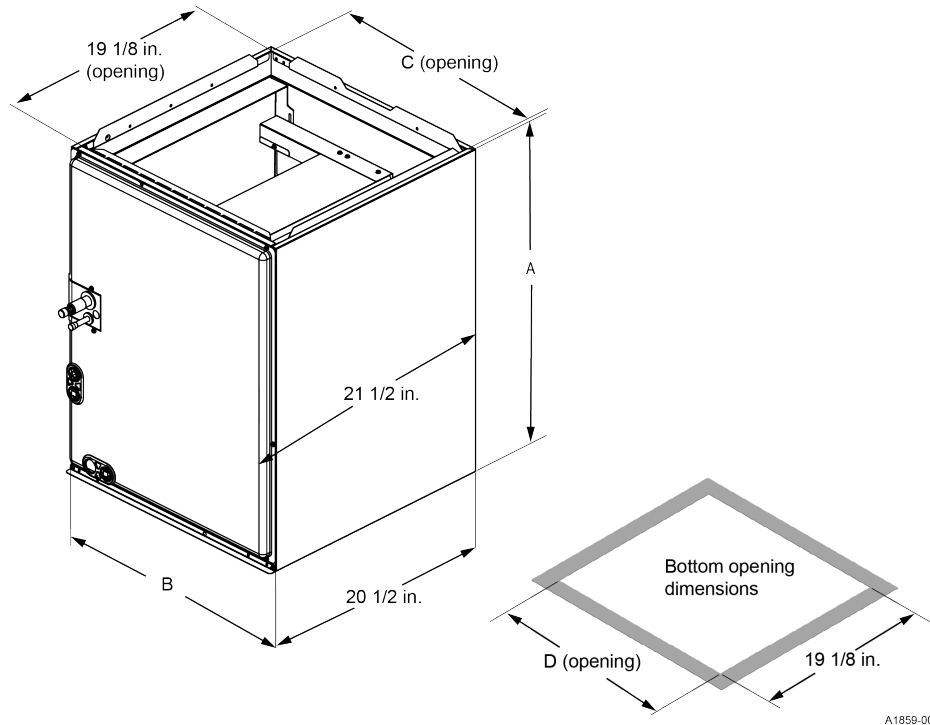

Table 2: Dimensions - XAM full-cased multi-position coil

Models	Dimensions				Weight (lb)		Expansion device	Refrigerant connections line size	
	Height	Width	Opening widths		Shipping	Operating		Liquid (in.)	Vapor (in.)
	A (in.)	B (in.)	C (in.)	D (in.)					
XAMB24DE1N1	25 5/8	17 1/2	16 1/2	16 1/2	52	50	EEV	3/8	3/4
XAMB36DE2N1	25 5/8	17 1/2	16 1/2	16 1/2	52	50	EEV		
XAMC36DE2N1	27	21	20	20	60	58	EEV		
XAMC48HE3N1	39	21	20	20	80	78	EEV	7/8	
XAMD48HE3N1	39	24 1/2	23 1/2	23 1/2	86	84	EEV		
XAMC60HE4N1	39	21	20	20	80	78	EEV		
XAMD60HE4N1	39	24 1/2	23 1/2	23 1/2	86	84	EEV		

**Note:**

- Refrigerant line sizes may require larger lines for extended line lengths. Refer to application data part number 247077.
- The adapter fitting must be field-installed for any refrigeration piping sizes not shown in the table.
- Refer to the *Technical Guide* for the outdoor unit for the correct refrigeration piping size.



## Cooling capacity: XAM coils

**Table 3: Cooling capacity - XAM multi-position full-cased coil (coil only\*)**

Model	Rated CFM	Entering air dry/ wet bulb (°F)	MBH at evaporator temperature and corresponding R-410A pressure (°F/psig)			
			35/107.9	40/118.9	45/130.7	50/143.3
XAMB24D	800	85/72	72.6	64.6	55.8	46.3
		80/67	59.2	51.2	42.4	33.4
		75/62	47.0	38.9	30.6	21.4
		70/57	35.9	28.1	19.8	15.1
XAMB36D	1200	85/72	80.2	72.1	62.8	52.0
		80/67	65.5	57.2	47.4	36.5
		75/62	52.0	43.5	33.4	22.2
		70/57	39.9	30.9	22.1	16.8
XAMC36D	1200	85/72	80.2	72.1	62.8	52.0
		80/67	65.5	57.2	47.4	36.5
		75/62	52.0	43.5	33.4	22.2
		70/57	39.9	30.9	22.1	16.8
XAMC48H	1600	85/72	101.0	96.8	89.7	76.0
		80/67	94.8	84.7	70.3	54.6
		75/62	78.2	64.7	50.4	34.6
		70/57	59.8	46.6	33.2	25.9
XAMD48H	1600	85/72	101.0	96.8	89.7	76.0
		80/67	94.8	84.7	70.3	54.6
		75/62	78.2	64.7	50.4	34.6
		70/57	59.8	46.6	33.2	25.9
XAMC60H	1800	85/72	102.4	91.9	79.8	66.3
		80/67	83.7	72.6	60.3	47.3
		75/62	66.4	54.9	43.1	29.0
		70/57	50.5	39.3	27.5	20.7
XAMD60H	1800	85/72	109.1	98.2	85.3	71.0
		80/67	89.0	77.6	64.7	50.6
		75/62	71.1	58.9	46.2	30.4
		70/57	54.1	42.2	29.8	22.5

① **Note:** \*Refer to the condensing unit or heat pump *Technical Guide* for the total cooling capacity and sensible capacity.

## Application factors

**Table 4: Application factors - rated CFM versus actual CFM - XAF, XAH, and XAU coils**

% of rated airflow (CFM)*	80%	90%	100%	110%	120%
Capacity factor	0.96	0.98	1	1.02	1.03

① **Note:** \*Do not exceed the minimum and maximum CFM limits shown in , , and .

## Application limitations

These units must be installed in accordance with all national and local safety codes.

Airflow must be within the minimum and maximum limits approved for electric heat, indoor coils, and outdoor units.

## Static pressure versus airflow based on wet coil: XAM coils

**Table 5: Static pressure versus airflow based on wet coil - XAM multi-position full-cased A coil**

Model	Airflow	Static
XAMB24D	700	0.22
	800	0.25
	900	0.29
XAMB36D	1050	0.36
	1200	0.45
	1350	0.54
XAMC36D	1050	0.26
	1200	0.31
	1350	0.37
XAMC48H	1400	0.17
	1600	0.24
	1800	0.31
XAMD48H	1400	0.23
	1600	0.27
	1800	0.33
XAMC60H	1550	0.24
	1800	0.33
	2050	0.43
XAMD60H	1550	0.29
	1800	0.35
	2050	0.42

## Coil technical data: XAM coils

**Table 6: Coil technical data - XAM multi-position full-cased A coil**

Model	Application	Refrig. conn. types	Face area (sq. ft)	Rows deep	Fins per in.	Coil size	Tube geometry	Tube diameter	Fin type	Shipping weight (lb)	Installed weight (lb)
XAMB24DE1N1	Cooling/heat pump	Sweat	4.7	3	14	(2) 20 x 17	1 x 0.675	3/8	Lanced	49	48
XAMB36DE2N1	Cooling/heat pump	Sweat	4.7	3	14	(2) 20 x 17	1 x 0.675	3/8	Lanced	49	48
XAMC36DE2N1	Cooling/heat pump	Sweat	4.7	3	14	(2) 20 x 17	1 x 0.675	3/8	Lanced	49	47
XAMC48HE3N1	Cooling/heat pump	Sweat	7.6	3	12	(2) 32 x 17	1 x 0.675	3/8	Lanced	72	70
XAMD48HE3N1	Cooling/heat pump	Sweat	7.6	3	12	(2) 32 x 17	1 x 0.675	3/8	Lanced	76	74
XAMC60HE4N1	Cooling/heat pump	Sweat	7.6	3	12	(2) 32 x 17	1 x 0.675	3/8	Lanced	72	70
XAMD60HE4N1	Cooling/heat pump	Sweat	7.6	3	12	(2) 32 x 17	1 x 0.675	3/8	Lanced	76	74

## Airflow data: XAM coils

**Table 7: XAM airflow data (CFM) - upflow**

Models	CFM								
	400	600	800	1000	1200	1400	1600	1800	2000
	External static pressure (in. W.C.)								
XAMB24D	0.04	0.07	0.11	0.15	0.20	—	—	—	—
XAMB36D	0.04	0.07	0.11	0.15	0.20	—	—	—	—
XAMC36D	0.05	0.11	0.17	0.25	0.35	0.48	—	—	—
XAMC48H	0.03	0.06	0.09	0.13	0.19	0.25	0.33	0.41	0.50
XAMD48H	0.02	0.04	0.07	0.09	0.13	0.18	0.23	0.28	0.34
XAMC60H	0.03	0.06	0.09	0.13	0.19	0.25	0.33	0.41	0.50
XAMD60H	0.02	0.04	0.07	0.09	0.13	0.18	0.23	0.28	0.34

**Note:**

- Airflow data is for dry coil conditions only, tested without filters.
- For optimal performance, external static pressures of 0.2 in. W.C. to 0.6 in. W.C. are recommended. Applications above 0.6 in. W.C. are not recommended.

---

Subject to change without notice. Published in U.S.A. Copyright © 2023 by Johnson Controls. All rights reserved.